



MID-RISE SCISSOR MINI 30

AUTOMOTIVE AND LIGHT TRUCK GENERAL SERVICE

DESIGNED AND BUILT IN ITALY, AND USED BY THE WORLD'S PREMIUM CAR MANUFACTURERS.

MID-RISE SCISSOR MINI 30

6,600 LB. / 3.0T CAPACITY

**COMPACT DESIGN IDEAL FOR TIRES, BRAKES,
BODY REPAIR, & FAST LUBE**



FEATURES



▲
Air Release Mechanical Locking

OPTIONAL



▲
Light Truck Frame Adapter

MID-RISE SCISSOR MINI 30

6,600 LB. / 3.0T CAPACITY

AT OMER USA, OUR GOAL IS TO BUILD LIFTS THAT LAST LONGER, PERFORM BETTER, AND COST LESS TO OPERATE

SPECIFICATIONS

Capacity	6,600 lb. / 3000 kg
Power Supply	220V 60hz 1 ph 23 amp 2HP/ 1.5 kw
Operating Noise Level	<80 db
Lifting Time	20 secs. raised/ 20 secs. lowered
Overall Width	78-3/4" / 2000mm
Overall Length	86-1/2" / 2200mm
Drive-Over Height	4-1/8" / 105mm
Overall Lifting Height	39-3/8" / 1000mm (42" / 1066mm with adapters)
# of Mechanical Locks	5
Lock Release	Air-cylinder lock release
Finish	Double-bake coat
Height Adapters	2" / 50 mm Rubber covered blocks
Lifting Pad Dimensions	61" to 82-1/2" Extended x 23-1/2" wide / 1550 to 2100mm Extended x 597mm wide
Equalization	Master / Slave System
Available In Flush-Mount	Yes
Pull-Out Deck Extension	Yes
Optional Light Truck Frame Adapter	Yes
Shipping Weight	1540 lb. / 700kg
Country Of Manufacture	Italy
Approvals UL/CSA/CE	Yes

FEATURES

- Compact design - rugged construction - Small foot print takes up less bay space while still allowing best-in-class weight capacity. Only 78 3/4" / 2000mm wide x 86 1/2" / 2200mm long.
- Versatility and ease of use - Ideal for small, compact cars up to light duty trucks, with pull out extensions allowing for ease-of-use on short or long wheelbase vehicles. No tie bar or floor obstruction.
- Master Slave style control stays level all the time - Thanks to single cylinder with dual chamber, unit stays level all the time. No electronic sensors required on the lift.
- Lower maintenance - less downtime - No electronic sensors, no equalization valve, extra-large pins with accessible grease fittings makes this an ideal lift for higher volume shops who require less downtime.
- Built for safety - 5 locking positions ensure side to side stability and eliminates accidental lowering of the lift. Single-point air cylinder lock release.
- Unobstructed access - Open front and rear construction with no tie bars or torsion rods allows for unobstructed access to the underside of most vehicles, with 27" / 686mm to 38" / 965mm of working area between the superstructures.
- Easy vehicle spotting - The flat deck platform and "spotting blocks" allows quick set-up by the operator, increasing bay productivity.
- Low profile approach ramps or flush mount options - The low profile ramps 4-1/8" / 105mm collapsed height allow for accessibility of smaller compact cars while still allowing for heavier loads. The lift can also be flush mounted for ultimate productivity and space saving bay solutions.

EQUIPMENT FOOTPRINT

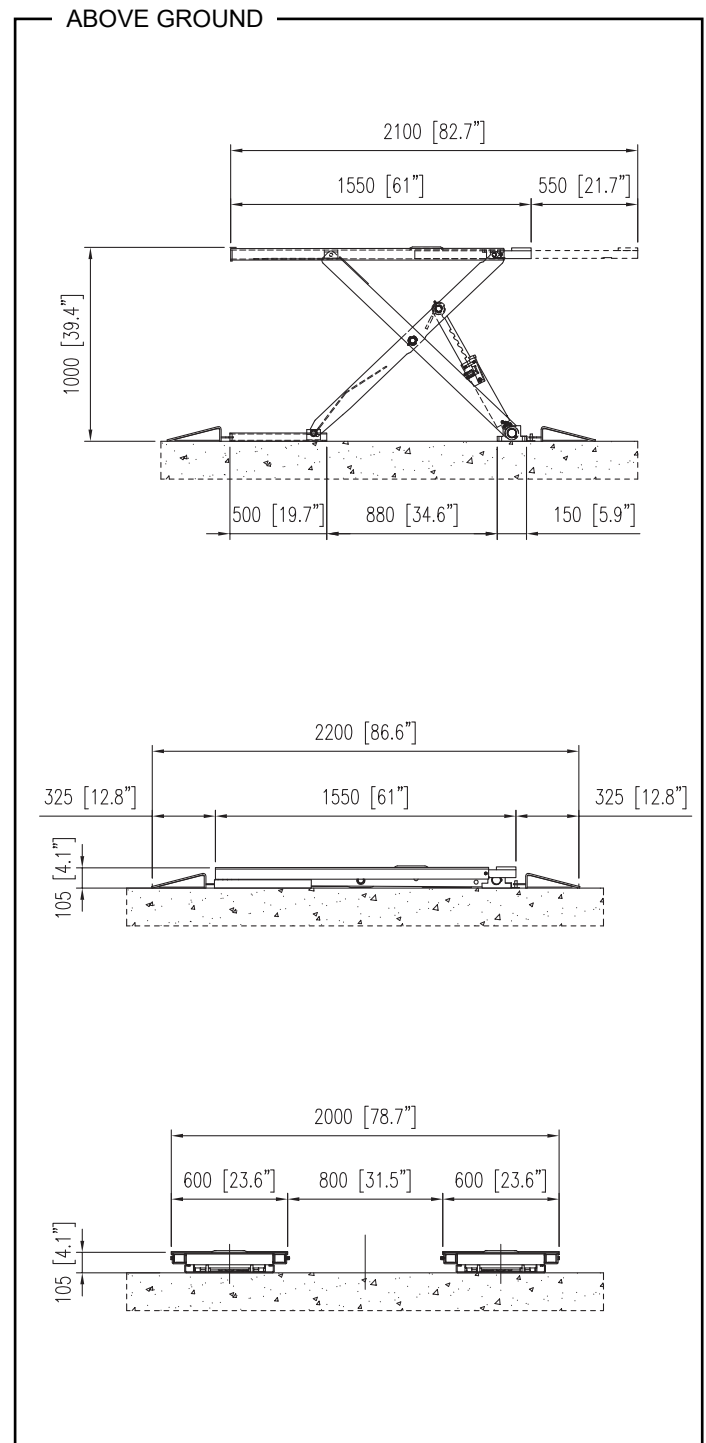

CONTACT US NOW

WWW.OMERINC.COM

CALL +1(470) 275-5919

